

# 1.5 kW — 14 kW SINGLE PHASE

## UltraLITE MODEL ELU

### Centralized Emergency Lighting Inverters

True no-break system, with regulated output and transient voltage protection for LED lighting, electronic ballasts, as well as all other existing and future lighting applications.

Peak overload capability up to 1400% to accommodate inrush current from LED fixtures / drivers!

Meets NFPA 101, 111, NEC, IBC and local codes.

#### Applications:

- Schools / Universities / Dormitories
- Security / Public Address Systems
- Arenas / Stadiums
- Subways / Mass Transit
- Parking Structures / Garages
- Hospitals / Clinics
- Office Buildings
- Shopping Malls
- Airport Terminals
- Casinos / Resorts
- Hotels / Motels
- Apartment Buildings
- Correctional Facilities



UL 924 Listed / C-UL Listed to CSA C22.2 No. 141-10  
UL 1778 Listed / C-UL Listed to CSA C22.2 No. 107.1-01



**CONTROLLED POWER COMPANY**

# EMERGENCY LIGHTING REQUIREMENTS

## The “UltraLITE, Model ELU” = Life Safety

Apart from the existing emergency lighting codes, many U.S. cities and states have adopted legislation that requires buildings with 5 or more units of occupancy to have a **centralized emergency lighting system**, where single-point operation controls a facility’s many smaller circuits, and all testing and record-keeping of the emergency power equipment is performed from one location.

Meeting stringent requirements in construction and performance, Controlled Power Company’s self-diagnostic, self-testing, **UltraLITE centralized emergency lighting inverters** are UL 924 listed as “Emergency Lighting Equipment” and “Auxiliary Power Supplies”, as well as NFPA compliant as “Life Safety Equipment”.

The **UltraLITE** offers more security and versatility to meet illumination requirements, and is the perfect complement for all life safety and lighting applications — “the universal solution”.

Our inverter technology effectively maintains critical equipment with extended brownout protection, tight voltage regulation, and power conditioning. Tight voltage regulation assures that facility egress lumens are maintained 100% at emergency lighting fixtures, in all modes of operation, and also extends ballast, LED driver, and lamp life.

## Major Advantages Of The “UltraLITE, Model ELU”

### Design Flexibility

Using existing fixtures for emergency lighting and egress assures compliance with minimum illumination code requirements. Extensive combinations of input and output voltages, timed off bus with remote “command on” control, automatic battery testing, and control device override options make the **UltraLITE** one of the most versatile and dependable lighting inverter systems in the market.

### Single Point Operation / Maintenance

One central inverter controls many smaller circuits. Cost-effective, single-point operation provides a common battery pack, and enables all maintenance to be performed and records to be logged from a single location. Additional benefits include:

- Egress lighting integrity test.
- Hot-swappable battery replacement.
- Standard internal bypass.
- Maintenance-free, standard 15-year pro-rated batteries.

### Premium Power And Voltage Regulation

Maintains proper operating voltage for HID and high-pressure sodium lighting, as well as electronic ballast and LED lighting, resulting in:

- Voltage sag and surge protection.
- Longer wire runs without upsizing the wire. Regulated voltage source minimizes voltage drop.
- Less-frequent replacement of ballast, LED drivers, and lamps.
- Facility egress lumens are maintained 100% (will not diminish) over the full 90 minutes of emergency power.

### Generator-Compatible

The **UltraLITE** is listed “UL924 Auxiliary Power Supplies”, and is suitable to provide uninterrupted back-up power until a generator starts. Even with an extremely distorted input waveform, the output of the **UltraLITE** delivers a clean sinewave, with no more than 3% THD, without switching to batteries. This feature also extends ballast, LED driver, and lamp life.

### Reduced Utility Expense

Energy conservation continues to be a prevalent issue. The **UltraLITE** provides several energy-saving solutions without compromising life safety requirements. Use of our optional **ZoneSaver-2™**, “emergency lighting control unit”:

- Allows for local control of emergency lighting fixtures to reduce / eliminate unnecessary night-light circuits and “always on” lighting loads.
- Allows for automatic bypassing of the local control device during NFPA-mandated test periods.
- Provides multiple, independent zone sensing abilities to reduce / eliminate unnecessary multiple-floor and multiple building-wing illumination. (Refer to the illustration to the left.)

All of these advantages result in the best reliability and net performance of your lighting system!

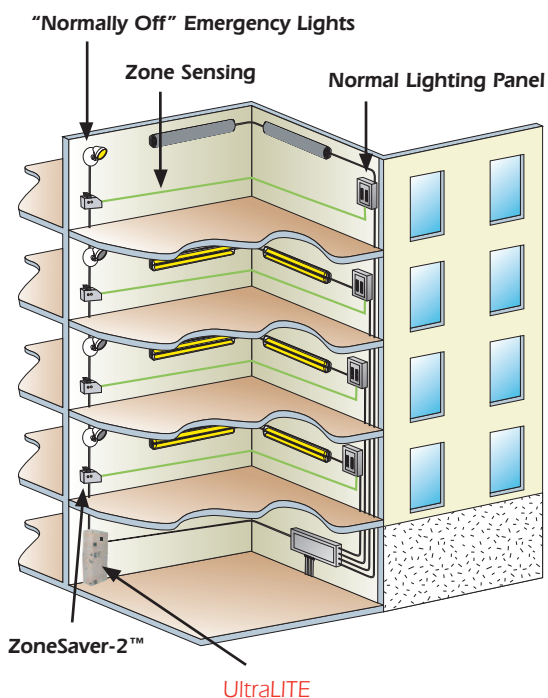

# SYSTEM DESCRIPTION & SPECIFICATIONS

Controlled Power Company engineers and manufactures the industry's highest quality **centralized emergency lighting inverters**, capitalizing on 4 decades of expertise. We have an enviable reputation for quality, which is reflected in the design, workmanship, and performance of our products.

Providing a seamless transfer to back-up power for your emergency lighting system, the **UltraLITE** is compatible with all fixtures including LED, HID, metal halide, high-pressure sodium, quartz / mercury vapor, halogen, fluorescent, and incandescent lighting applications. The voltage regulation and performance characteristics of the **UltraLITE** offer a significant advantage over competing products.

## Features & Benefits

- Uninterrupted, regulated, continuous sinewave output for use with “normally on” lighting fixtures and exit lamps, LED and HID compatible.
- Standby output for use with “normally off” emergency lighting fixtures.
- Pulse width modulation and IGBT technology provide tight output voltage regulation.
- Delivers highly-filtered, regulated, and spike-free power to emergency lighting fixtures and “Life Safety” devices.
- True, online double-conversion topology provides conditioned, regulated power and 100% reliability to emergency lighting loads.
- Auxiliary input command.
- High-speed static bypass.
- System approved for 42k AIC rated source.
- Variable-range logic provides added security during deep brownout conditions, without battery consumption — thus assuring that the batteries will be at full capacity for a power outage.
- Field-modifiable distribution.
- Short-circuit protected.
- NEMA 1 enclosure.
- Generator-compatible.
- 4-stage, temperature compensating smart charge.
- Optional control device override (wall switch, occupancy sensor, dimmer, etc).
- Optional zone sensing.
- Optional remote status panel and automatic phone dialer.
- Optional network connectivity.

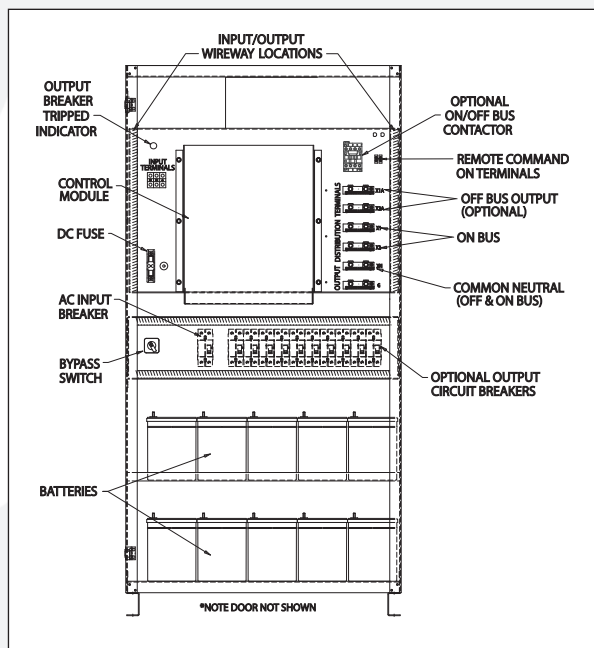

## Safety

- UL 924 listed Emergency Lighting Equipment
- UL 924 listed Auxiliary Lighting and Power Equipment
- UL 1778 listed Uninterruptible Power Supplies
- C-UL listed to CSA C22.2 No. 141-10 Emergency Lighting Equipment
- C-UL listed to CSA standard C22.2 No. 107.1-01 General Use Power Supplies
- CCMC Approval # 13428-R (Canadian Construction Materials Centre)
- NFPA 101, NFPA 111, NEC, and local codes

## Product Specifications

- Input Operating Voltage Range: +12%, -30% typical, load-dependent without battery usage
- Input Frequency: 60 Hz,  $\pm 2.5\%$
- Input Current Harmonic Distortion: <5% THD
- Input Power Factor Correction: > .99 PF
- Output Regulation: Typically better than  $\pm 1.5\%$
- Overload Rating: Up to 125% for 30 cycles, 150% for 4 cycles when fed from the AC power source, or on battery (without use of static bypass).
- LED Inrush Rating: Peak overload capability up to 1400% to accommodate inrush current from LED fixtures/drivers (without use of static bypass).
- Standard Unit Operating Temperature:  
UL and C-UL<sup>1</sup> listed as 0° C to 40° C.
- Noise Attenuation:<sup>2</sup> Common Mode: 120 dB  
Transverse Mode: 70 dB

<sup>1</sup> C-UL listed to CSA C22.2 No. 141-10 Emergency Lighting Equipment at 20° C to 40° C.

<sup>2</sup> Models supplied with isolation transformer.

## Standards

- ANSI / IEEE C62.41 Category B3
- NFPA 101
- NFPA 111 Stored Electrical Energy Emergency and Standby Power Systems. Meets SEPSS / ECE / Level 1 and Level 2 criteria for types O, U, A, B, and 10; and Classes up to and including Class 1.5
- NFPA 70 National Electric Code
- FCC Class A limits, 47 C.F.R. Part 15, Subparts A, B
- IEC 555

# STANDARD COMMUNICATIONS & DIAGNOSTICS

## Display Monitor & Diagnostics

The **UltraLITE**'s full-featured monitoring system includes:

- Self-test diagnostics.
- Automatic battery test.
- Audible alarms.
- Protected ON / OFF switch.
- Push-to-test.

The **UltraLITE** also has a full complement of indicators:

- Percent load.
- High / low / normal input voltage.
- On battery.
- Percent of battery.
- Check battery.
- Bypass status.
- Alarm status.

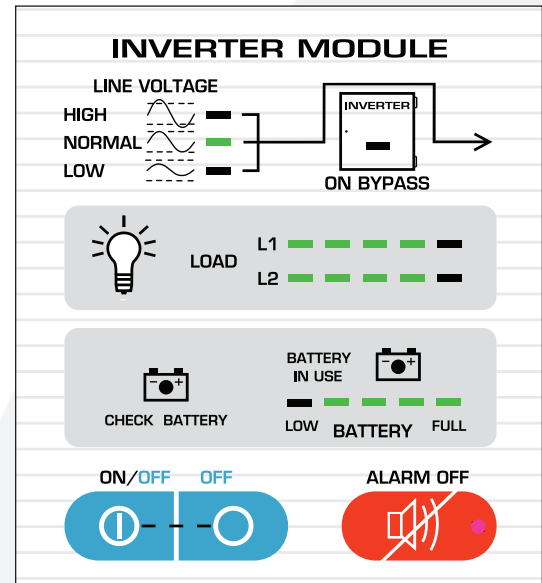

## Communications & Diagnostics

- Integral status and alarm panel.
- Remote communications via alarm signals or RS232.

## Batteries

- Integral 90 minute, maintenance-free batteries.
- Automatic, pre-programmed battery testing, including self-diagnostics.
- Small footprint and self-contained batteries maximize floor space.
- Rapid recharge, per UL 924 requirements.

## Optional Output Distribution

- Output Circuit Breaker Pole Spaces Available:  
Without Trip Indicator Alarm / Light: 20  
With Trip Indicator Alarm / Light: 10

Optional Output Distribution Circuit Breakers

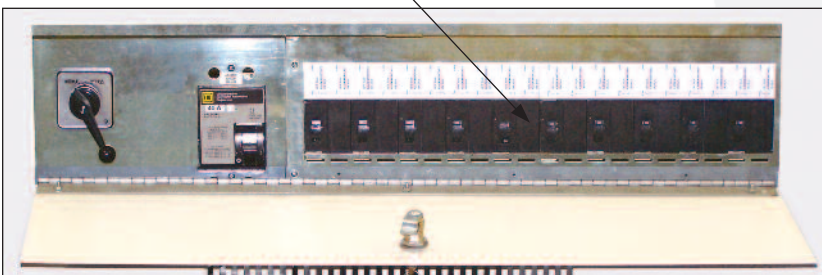

Hinged, key-lockable, drop-down panel allows front access to standard input breaker, inverter bypass switch, and optional output distribution circuit breakers.

## Simplified Maintenance For Centralized Lighting

- Single-point operation. One central inverter controls many lighting circuits.
- Centralized system significantly reduces man-hours required for monthly testing.
- All testing and record-keeping are performed from one location.
- Secure bypass switch allows for uninterrupted bypass of the inverter to utility power for any maintenance situation.
- Eliminates vandalism potential that exists with wall-pack emergency lighting systems.
- Besides its cooling fans, the **UltraLITE** has no mechanical or moving parts.
- Low cost of ownership resulting from: high inverter efficiency, lower maintenance, and optional control device override.



## Advanced Digital Monitoring — The Intellistat TS™

The user-friendly **Intellistat TS™** monitor provides quick, full-access to all of the inverter's features, allows all programming to be done directly from the touch-screen display, and provides complete system diagnostics and testing. A color, TFT, high resolution touch-screen display indicates all the electrical parameters, as well as the functional status of the inverter. The touch-screen display allows the entry of the date / time values, system setpoints, and password information into the monitor, without the need for an external computer and cable.

The **Intellistat TS's** features include:

- LCD display of all electrical parameters.
- NFPA-compliant automatic battery testing / logging.
- User-programmable automatic system testing.
- System alarm annunciation.
- Audible alarm with alarm silence.
- Alarm status display.
- Programmable alarm set-points.
- Date and time display.
- Auto-logging of test results and abnormal events.
- Multi-layer password protection.
- Programmable local interfaces.
- Logs up to 50 events.
- Non-volatile clock and memory.
- Remote monitoring capabilities.
- Optional reporting of test results via fax / e-mail / voice / webpage.
- Optional status notification via e-mail / cell-phone.

### Monitored Parameters

The **Intellistat TS** monitors the following parameters and inverter status indicators:

- Input voltage.
- Output voltage.
- Output current.
- Output VA.
- Output watts.
- Output power factor.
- Output percent load.
- Output frequency.
- Battery voltage.
- Battery charger current
- Percent battery time remaining.

### Alarms & Status

The **Intellistat TS** announces many alarms, including the following:

- High / low input voltage.
- High / low output voltage.
- High output VA (overload).
- \*Low output VA.
- High / low output frequency.
- High / low battery voltage.
- High battery charger current.
- System normal.
- General alarm.
- System on battery.
- Low battery warning.
- Low battery shutdown.
- Battery test in progress.
- Auto battery test failed / passed.
- Off bus status.
- DC charger fail / DC open.
- Output circuit breaker open.
- REPO shutdown.
- System in static bypass.
- System in manual bypass.

\* User-programmable limit referenced during automatic battery testing, to verify integrity of egress lighting.



The color touchscreen display on the **Intellistat TS** provides all electrical parameters, inverter status, programmable inverter and battery testing, and data-logging. Optional **NetMinder™** communications allow for remote monitoring and reporting. For more details, see the "Optional **NetMinder Communications**" description on Page 7.

### Egress Lighting Integrity Test

To satisfy NFPA-mandated periodic and annual requirements, the **Intellistat TS** automatically initiates the testing of all life safety circuits, regardless of egress lighting design ("always on" or "normally off"). The **Intellistat TS** then compares power consumption during the test period with user-defined load capacity, analyzes the data, and advises if service is required.

During these NFPA-mandated tests, a "test activated" contact may be used to activate one or more remotely installed **ZoneSaver-2** emergency lighting control units. When activated, the **ZoneSaver-2** will feed emergency power to egress lighting that is normally off, or dimmed / turned off via a local control device. This option allows for automatic testing of the locally controlled life safety circuit and the **ZoneSaver-2** control unit.

### Automatic System Tests

The **Intellistat TS** automatically performs a user-defined (date and time) 5-minute system test every 30 or 90 days. It also performs user-defined (date and time) 30-, 60-, or 90-minute, or 2- or 4-hour annual system tests. For all of these tests, the **Intellistat TS** logs the test results with date and time, as well as a "pass" or "fail" indication.

### Manual System Tests

The **Intellistat TS** also allows the user to manually invoke a user-defined system test for 30-, 60-, or 90-minutes, as well as 2- or 4-hours. A 1-minute or 5-minute manual test is also available for "spot inspections".

# DESIGN FLEXIBILITIES & PROVEN SOLUTIONS

The **UltraLITE** offers design flexibilities which are not provided with competing lighting inverters:

## Multi-Voltage Capabilities (Figure 1)

The **UltraLITE** is a power factor corrected, uninterruptible, double-conversion system, with a static transfer switch for maximum reliability. An internal make-before-break bypass switch maintains the proper output voltage in bypass, even “dual output voltage” configurations. The **UltraLITE** accepts and distributes the industry’s broadest range of voltages, from 120 VAC – 600 VAC.

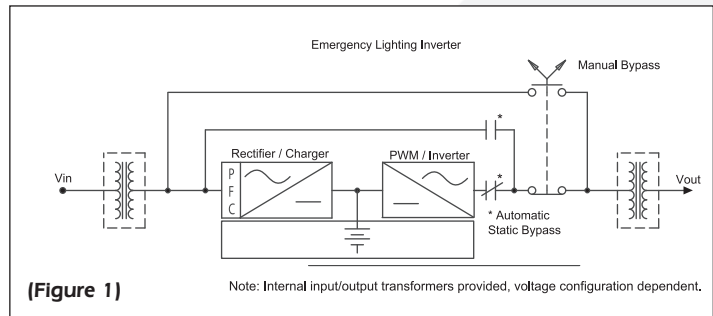

## UL 924 Auxiliary Lighting and Power Equipment (Figure 2)

In addition to being UL 924 listed with 90 minutes as Emergency Lighting Equipment, the **UltraLITE** is UL 924 listed with other battery runtimes as Auxiliary Lighting and Power Equipment. When provided with 10-15 minutes of battery, the **UltraLITE** is the perfect complement to generator-based emergency lighting systems. The **UltraLITE** provides uninterruptible, regulated power to critical lighting systems and other life safety related equipment. Additionally, for uncompromised personal safety, critical “always on” lights remain illuminated, and the generator synchronization delay is eliminated.

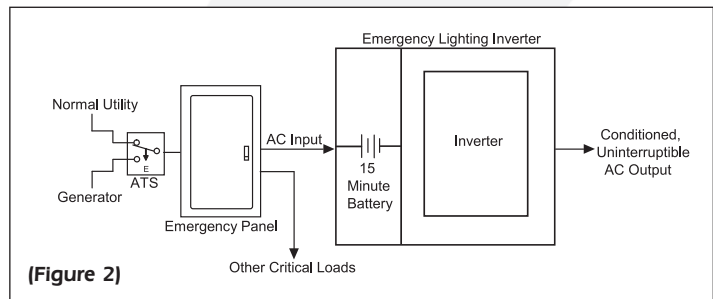

## Remote Input Command (Figure 3)

Allows the monitoring of multiple locations and events within the emergency lighting system, and may be activated by a signal from any specified monitoring point. If an unacceptable condition exists at one or more of the locations being monitored, the open contact energizes the “Normally Off” bus, thus illuminating the “Normally Off” emergency lights. Likewise, when normal conditions are restored, the “Normally Off” bus is de-energized, and the emergency lights return to their “Normally Off” state.

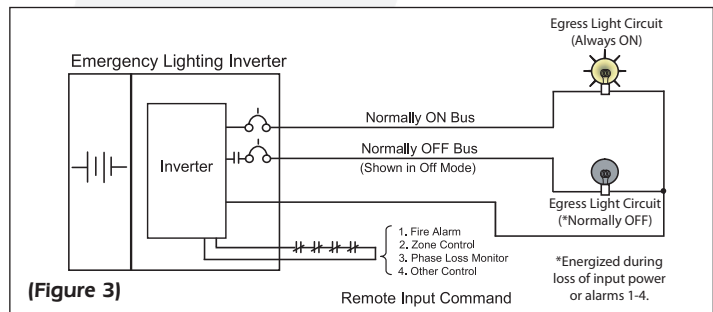

## Local Control Device Override (Figure 4)

The **UltraLITE** allows for user control of emergency egress lighting. This includes (but is not limited to) occupancy sensors, wall switches, and dimmer switches. Not only is this approach more reliable, it also saves money because it reduces costly “always on” circuits.

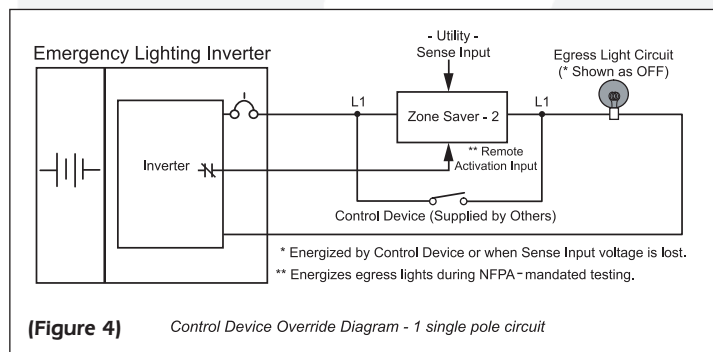

## Zone Sensing (Figure 5)

The most cost-effective emergency lighting applications allow for independent activation of “Normally Off” fixtures in multi-floor or multi-use facilities. The **UltraLITE** uses **ZoneSaver-2™** to monitor normal lighting circuit panels for each floor / zone. Loss of power at the normal lighting circuit panel, or activation by the inverter’s periodic or annual test active contact, energizes the emergency lighting for that floor / zone only.

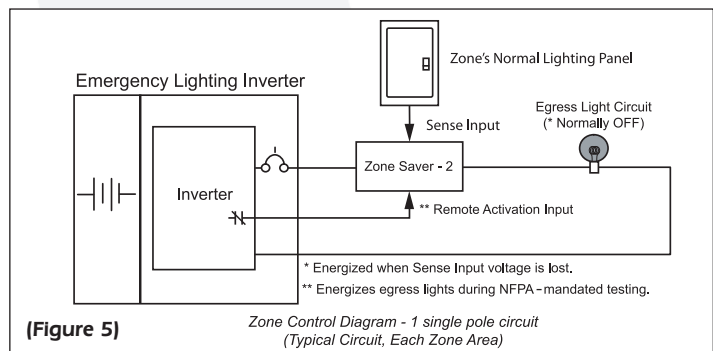

# INVERTER OPTIONS & CABINET CONFIGURATIONS

The "UltraLITE" offers a variety of special options:

## Normally Off Bus

Provides standby power to "normally off" emergency lamps, at the same or different voltage than "normally on" emergency lamps. When utility power is lost or voltage is inadequate, emergency power is supplied to "normally off" lights, providing a safe means of egress.

## Timed Normally Off Bus

Functions the same as the **Normally Off Bus** (above), but differs in that the "Transfer ON" and "Return OFF" times for the bus are programmable. This programmable feature is especially useful to prevent nuisance activation of emergency lighting during short-term power disturbances. Additionally, the return delay provides sufficient time for standard HID lighting recovery, factory-set at 15 minutes.

## Automatic Phone Dialer

Plugs into the communications port of the inverter, and can be programmed to notify personnel of alarm conditions. This small device can dial up to four (4) phone numbers (land, cell, pager); and records and delivers a custom voice message.

## Output Distribution Circuit Breakers

Meeting the need for flexible power distribution, circuit breakers can be added, subtracted, or moved without any complex mounting techniques. Output circuit breakers can be configured to supply power to different lighting loads at different voltages. Front-access to the standard input breaker and the optional output distribution circuit breakers is through a lockable drop-down panel door.

## Optional NetMinder Communications

The **NetMinder's** series of adapters integrate the **UltraLITE** into a BACnet/IP or BACnet MS/TP, Ethernet TCP/IP, MODBUS TCP, or MODBUS RS485 network with a specific IP address for Ethernet connected systems. The **NetMinder** provides remote monitoring of the inverter status, battery test pass/fail results, alarm conditions, and electrical measurements via a web browser, without the need for any external software. Remote notification of alarms and status are available via SNMP, e-mail, and network broadcast messaging. Temperature and humidity sensing interface are also available.

## Front Access Design

The **UltraLITE** has a compact, space-saving "footprint", and front access to accelerate installation, testing, and maintenance procedures. Standard, 15-year pro-rated batteries are either self-contained or in a user-friendly battery cabinet with easy-access lift-off doors. The "footprint" illustrations below assume unity power factor and 90 minutes runtime. Consult factory for additional front access cabinet configurations using alternative runtimes.

OUTPUT RATING	INVERTER (A)	BATTERY (B)
7.5kW - 10kW	36"W x 24"D	29"W x 24"D
12.5kW - 14kW		36"W x 27"D



# PRODUCT SELECTION GUIDE

## MODEL NUMBER GUIDE

PRODUCT	INPUT	OUTPUT	FREQ	kVA / kW	MONITOR	BATTERY	DISTRIBUTION	OFF BUSS
ELU - Lighting Inverter	A=120 J=277 L=208/120 G=240/120 V=347 D=480 E=600	A=120 J=277 Y=277/120 L=208/120 G=240/120 V=347/120	X=60Hz	Lighting Inverters 1.5 kW    7 kW 2.2 kW    7.5 kW 3 kW       8.5 kW 3.5 kW    10 kW 4.2 kW    12.5 kW 5 kW       13.5 kW 6 kW       14 kW	0=Standard 1=Intellistat TS	S=90m N=None or UPS Battery Option	0=None 1=Yes	0=None 1=Off Bus T=Timed Off Bus

NOTE: Consult factory for output distribution options.

ELU MODEL NUMBERS							
UL 924 MODELS	kVA / kW	WEIGHTS (LBS) <sup>1</sup> INPUT - OUTPUT VAC 60 Hz 120-120	WEIGHTS (LBS) <sup>1</sup> INPUT - OUTPUT VAC 60 Hz 277 - 277 277 - 277/120 347 - 347/120 480 - 277 480 - 277/120 600 - 347/120	WEIGHTS (LBS) <sup>1</sup> INPUT & OUTPUT VAC 60 Hz 208/120V 240/120V	WEIGHTS (LBS) <sup>1</sup> INPUT - OUTPUT VAC 60 Hz 480 - 240/120V 600 - 240/120V	FULL LOAD BTU'S / HOUR <sup>2</sup>	STANDBY MODE BTU'S / HOUR <sup>2</sup>
ELU-**X-1.5kW-1S **	1.5	898	1081	na	na	511	128
ELU-**X-2.2kW-1S **	2.2	898	1081	na	na	750	188
ELU-**X-3kW-1S **	3	1073	1256	1073	na	1023	256
ELU-**X-3.5kW-1S **	3.5	1073	1256	1073	na	1194	298
ELU-**X-4.2kW-1S **	4.2	1459	1645	1459	1645	2005	358
ELU-**X-5kW-1S **	5	1548	1734	1548	1734	2387	426
ELU-**X-6kW-1S **	6	na	2254	2004	2254	2864	512
ELU-**X-7kW-1S **	7	na	2254	2004	2254	3342	597
ELU-**X-7.5kW-1S **	7.5	na	2808	2630	2808	3581	639
ELU-**X-8.5kW-1S **	8.5	na	2898	2648	2898	4058	725
ELU-**X-10kW-1S **	10	na	3298	3048	3298	4774	853
ELU-**X-12.5kW-1S**	12.5	na	4124	3684	4124	5967	1065
ELU-**X-13.5kW-1S**	13.5	na	4134	3694	4134	6445	1151
ELU-**X-14kW-1S**	14	na	4576	4136	4576	6684	1194

VOLTAGE CONFIGURATIONS	
**X = Input - Output VAC, 60 Hz	Output KVA / kW
AA = 120 - 120 JJ = 277 - 277 JY = 277 - 277/120	1.5 kW - 5 kW 1.5 kW - 14 kW
LL = 208/120 - 208/120 GG = 240/120 - 240/120	3 kW - 14 kW
VV = 347 - 347/120 DG = 480 - 240/120 DJ = 480 - 277 DY = 480 - 277/120 EG = 600 - 240/120 EV = 600 - 347/120	4.2 kW - 14 kW

Notes: Each model includes 90 minutes back-up time, per UL 924 Emergency Lighting Equipment. Battery runtimes other than 90 minutes are available under UL 924 Auxiliary Lighting and Power Equipment – consult factory.

Models are also listed UL 1778 and C-UL Uninterruptible Power Supplies. Consult factory for specific applications and runtimes.

<sup>1</sup> Cabinet weights include the weight of batteries for standard 90 minutes runtime. Battery weights vary according to desired runtimes – consult factory for runtimes other than 90 minutes.

<sup>2</sup> BTU's are typical at rated load. Consult factory for maximum BTU's / hour ratings on specific models.

<sup>3</sup> Standby BTU's represent emergency lighting loads that are normally off or turned off via a local control device, used together with a UL 924 listed bypass relay. Stated BTU's for 120V, 208/120V, and 240/120V models. Consult factory for standby BTU's on other models.

Represented by:



**CONTROLLED POWER COMPANY**

"World's recognized authority in power treatment"

1955 Stephenson Hwy. Troy MI 48083

www.controlledpwr.com

email: info@controlledpwr.com

Phone: (248) 528-3700 Fax: (248) 528-0411

Call Toll Free: (800) 521-4792